

**PL8281
4CX15,000A
RADIAL BEAM
POWER TETRODE**



The PL8281/4CX15,000A is a ceramic/metal power tetrode intended for use in audio or radio frequency applications. It features a type of internal mechanical structure which results in high rf operating efficiency. Low rf losses in this structure permit operation at full ratings up to 110 MHz, and at reduced ratings up to 225 MHz.

The PL8281/4CX15,000A is also recommended for radio-frequency linear power amplifier service.

GENERAL CHARACTERISTICS¹

ELECTRICAL

Filament: Thoriated Tungsten

Voltage	6.3 + 0.3 V
Current @ 6.3 volts	160 A
Amplification Factor, average	
Grid to Screen	4.5
Direct Interelectrode Capacitance (cathode grounded) ²	
Cin	160 pF
Cout	24.5 pF
Cgp	1.5 pF
Direct Interelectrode Capacitance (grid and screen grounded) ²	
Cin	67.0 pF
Cout	25.5 pF
Cpk	0.2 pF
Maximum Frequency for Full Ratings (CW)	110 MHz

1. Characteristics and operating values are based on performance tests. These figures may change without notice as the result of additional data or product refinement. Penta should be consulted before using this information for final equipment design.
2. Capacitance values are for a cold tube as measured in a special shielded fixture in accordance with Electronic Industries Association Standard RS-191

Revised 6 August 2002



P E N T A L A B O R A T O R I E S
 9740 COZYCROFT AVENUE * CHATSWORTH * CALIFORNIA 91311
 (800) 421-4219 * (818) 882-3872 * FAX: (818) 882-3968

ELECTRON TUBES FOR INDUSTRY



PL8281/4CX15,000A

MECHANICAL

Maximum Overall Dimensions:	
Length	9.37 In; 23.81 cm
Diameter	7.58 In; 19.25 cm
Net Weight (approximate)	12.8 Lb; 5.8 kg
Operating Position	Axis Vertical , base up or down
Cooling	Forced Air
Operating Temperature Maximum:	
Ceramic/Metal Seals and Anode Core	250° C
Base	Special, Concentric
Recommended Air-System Sockets:	
LF or HF Applications	PSK-300A
VHF applications	PSK-360
Recommended Air Chimney, for use with SK-300 socket only	PSK-316
Available Screen Grid Bypass Capacitor Kit for SK-360 (8000 pF @ DCWV = 5000)	PSK-355
Available Anode Connector Clip	PACC-3

RADIO FREQUENCY LINEAR AMPLIFIER GRID DRIVEN CLASS AB1

ABSOLUTE MAXIMUM RATINGS:

DC Plate Voltage	10 Kilovolts
DC Screen Voltage	2.0 Kilovolts
DC Grid Voltage	-1.5 Kilovolts
DC Plate Current	6.0 Amperes
Plate Dissipation	15 Kilowatts
Screen Dissipation	450 Watts
Grid Dissipation	200 Watts

TYPICAL OPERATION

Peak Envelope or Modulation Crest Conditions

Plate Voltage	7.5	10.0	kVdc
Screen Voltage	1.5	1.5	dVdc
Grid Voltage #	-350	-370	Vdc
Zero-signal Plate Current	1.0	1.0	Adc
Single-tone Plate Current	4.0	4.25	Adc
Single-tone Screen Current*	170	150	mAdc
Peak rf Grid Voltage *	330	340	v
Plate Dissipation *	12.2	14.0	kW
Single-ton Plate Output Power *	20.8	28.5	kW
Resonant Load Impedance	865	1260	Ohms

* Approximate value.

Adjust for specified zero-signal plate current.



PL8281/4CX15,000A

RADIO FREQUENCY POWER AMPLIFIER OR OSCILLATOR

Class C Telegraphy or FM (Key-down Conditions)

ABSOLUTE MAXIMUM RATINGS:

DC Plate Voltage	10 Kilovolts
DC Screen Voltage	2.0 Kilovolts
DC Grid Voltage	-1.5 Kilovolts
DC Plate Current	5.0 Amperes
Plate Dissipation	15 Kilowatts
Screen Dissipation	450 Watts
Grid Dissipation	200 Watts

TYPICAL OPERATION

Plate Voltage	7.5	10.0	kVdc
Screen Voltage	750	750	Vdc
Grid Voltage	-510	-550	Vdc
Plate Current	4.65	4.55	Adc
Screen Current *	590	540	mAdc
Grid Current *	300	270	mAdc
Peak rf Grid Voltage *	730	790	v
Calculated Driving Power	220	220	W
Plate Dissipation *	8.1	9.0	kW
Plate Output Power *	26.7	36.5	kW

* Approximate value.

PLATE MODULATED RADIO FREQUENCY POWER AMPLIFIER - GRID DRIVEN

Class C Telephony - Carrier Conditions

ABSOLUTE MAXIMUM RATINGS:

DC Plate Voltage	8.0 Kilovolts
DC Screen Voltage	1.5 Kilovolts
DC Grid Voltage	-1.5 Kilovolts
DC Plate Current	4.0 Amperes
Plate Dissipation	10.0 Kilowatts
Screen Dissipation	450 Watts
Grid Dissipation	200 Watts



PL8281/4CX15,000A

TYPICAL OPERATION

Plate Voltage.	6.0	8.0	kVdc
Screen Voltage.	750	750	Vdc
Grid Voltage	-600	-640	Vdc
Plate Current.	3.75	3.65	Adc
Screen Current *	450	430	mAdc
Grid Current *	180	180	mAdc
Peak audio freq. screen voltage * (for 100% modulation)	740	710	v
Peak rf Grid Voltage	800	840	v
Calculated Driving Power	150	150	W
Plate Dissipation *	5.1	5.8	kW
Plate Output Power *	17.4	23.5	kW

* Approximate value.

AUDIO FREQUENCY POWER AMPLIFIER OR MODULATOR - GRID DRIVEN Class AB1 (sinusoidal wave)

ABSOLUTE MAXIMUM RATINGS (per tube)

DC Plate Voltage	10 Kilovolts
DC Screen Voltage	2.0 Kilovolts
DC Grid Voltage	-1.5 Kilovolts
DC Plate Current	6.0 Amperes
Plate Dissipation	15 Kilowatts
Screen Dissipation	450 Watts
Grid Dissipation	200 Watts

TYPICAL OPERATION

Plate Voltage.	7.5	10.0	kVdc
Screen Voltage.	1.5	1.5	kVdc
Grid Voltage #.	-350	-370	Vdc
Zero-signal Plate Current ##	1.0	1.0	Adc
Maximum-signal Plate Current	8.8	8.5	Adc
Maximum-signal Screen Current *	340	300	mAdc
Peak Audio Freq. Grid Voltage *	330	340	v
Maximum-Signal Plate Dissipation ##	12.2	14.0	kW
Plate Output Power *	41.6	57.0	kW
Load Resistance (plate to plate)	1730	2520	Ohms

* Approximate value. # Adjust for specified zero-signal plate current. ## Per Tube.



PL8281/4CX15,000A

TELEVISION LINEAR AMPLIFIER

Cathode Driven

ABSOLUTE MAXIMUM RATINGS (110 MHz to 225 MHz)

DC Plate Voltage	6.5 Kilovolts
DC Screen Voltage	1.5 Kilovolts
DC Plate Current	5.0 Kilovolts
Plate Dissipation	15 Kilowatts
Screen Dissipation	450 Watts
Grid Dissipation	200 Watts

TYPICAL OPERATION, Composite Signal Black Level Unless Otherwise Stated

Plate Voltage	5.0	6.0	kVdc
Screen Voltage	500	700	Vdc
Grid Voltage *	-160	-180	Vdc
Plate Current (Zero-signal)	500	650	mAdc
Plate Current	2.8	3.33	Adc
Grid Current *	75	35	mAdc
Screen Current *	60	40	mAdc
Peak Cathode Voltage (peak synch)	310	345	v
Cathode Driving Power (peak synch)	975	1350	W
Plate Output Power (peak synch)	11.0	16.5	kW
Plate Load Resistance	600	600	Ohms

* Approximate value.

TYPICAL OPERATION values are obtained by calculation from published characteristic curves. To obtain the specified plate current at the specified bias, screen, and plate voltages, adjustment of the rf grid voltage is assumed. If this procedure is followed, there will be little variation in output power when the tube is replaced, even though there may be some variation in grid and screen currents. The grid and screen currents which occur when the desired plate current is obtained are incidental and vary from tube to tube. These current variations cause no performance degradation providing the circuit maintains the correct voltage in the presence of the current variations.



PL8281/4CX15,000A

RANGE VALUES FOR EQUIPMENT DESIGN

	MIN.	MAX.	
Filament Current, at 6.3 volts	152	168	A
Interelectrode Capacitances, cathode grounded ¹			
Cin	157.0	167.0	pF
Cout	23.0	27.0	pF
Cgp	---	2.0	pF
Interelectrode Capacitances, grid & screen grounded ¹			
Cin	62.0	70.0	pF
Cout	24.0	27.5	pF
Cpk	---	0.3	pF

1. Capacitance values are for a cold tube in a special shielded fixture in accordance with Electronic Industries Association Standard RS-191.

OPERATING HAZARDS

Proper use and safe operating practices with respect to power tubes are the responsibility of equipment manufacturers and users of such tubes. All persons who work with or are exposed to power tubes or equipment which utilizes such tubes must take precautions to protect themselves against possible serious bodily injury. Do not be careless around such products.

The operation of this tube may involve the following hazards, any one of which, in the absence of safe operating practices and precautions, could result in serious harm to personnel:

- a. HIGH VOLTAGE - Normal operating voltages can be deadly. Remember that HIGH VOLTAGE CAN KILL.
- b. LOW-VOLTAGE HIGH-CURRENT CIRCUITS - personal jewelry, such as rings, should not be worn when working with filament contacts or connectors as a short circuit can produce very high current and melting, resulting in severe burns.
- c. RF RADIATION - Exposure to strong rf fields should be avoided, even at relatively low frequencies. The dangers of rf radiation are more severe at UHF and microwave frequencies and can cause serious bodily and eye injuries. CARDIAC PACEMAKERS MAY BE EFFECTED.
- d. HOT SURFACES - Surfaces of tubes can reach temperatures of several hundred C and cause serious burns if touched for several minutes after all power is removed.



PL8281/4CX15,000A

DIMENSIONAL DATA						
DIM	INCHES			MILLIMETERS		
	MIN	MAX	REF	MIN	MAX	REF
A	7.460	7.580		189.48	192.53	
B	.855	.895		21.72	22.73	
C	.600	.760		15.24	19.30	
D	1.896	1.936		48.16	49.17	
E	3.133	3.173		79.58	80.59	
F	3.792	3.832		96.32	97.33	
G	3.980	4.020		101.09	102.11	
H	.188			4.78		
J	.188			4.78		
K	.188			4.78		
M	4.550	4.783		115.57	121.49	
M	2.412	2.788		61.26	70.82	
P	9.000	9.375		228.60	238.13	
S	3.560	3.684		90.42	93.57	
T	.375			9.53		
U	4.406	4.468		111.91	113.49	
V	3.718	3.781		94.44	96.04	
W	.219			5.56		

NOTES:

1. REF DIMENSIONS ARE FOR INFO ONLY & ARE NOT REQUIRED FOR INSPECTION PURPOSES.
2. DIMENSIONS IN [] ARE MILLIMETERS.
3. *CONTACT SURFACE.
4. OPTIMUM FILAMENT & GRID CONNECTOR HEIGHTS FOR SOCKET DESIGN PURPOSES.

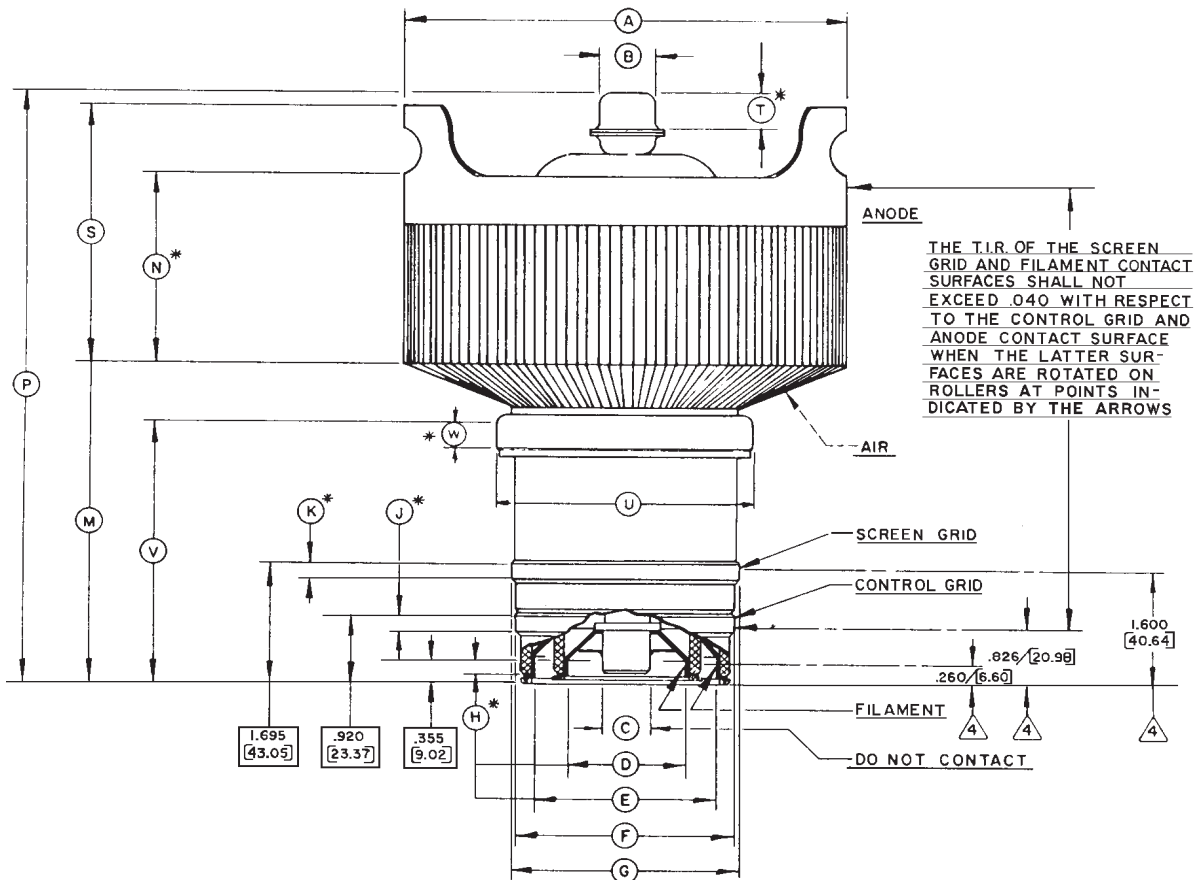



PL8281/4CX15,000A

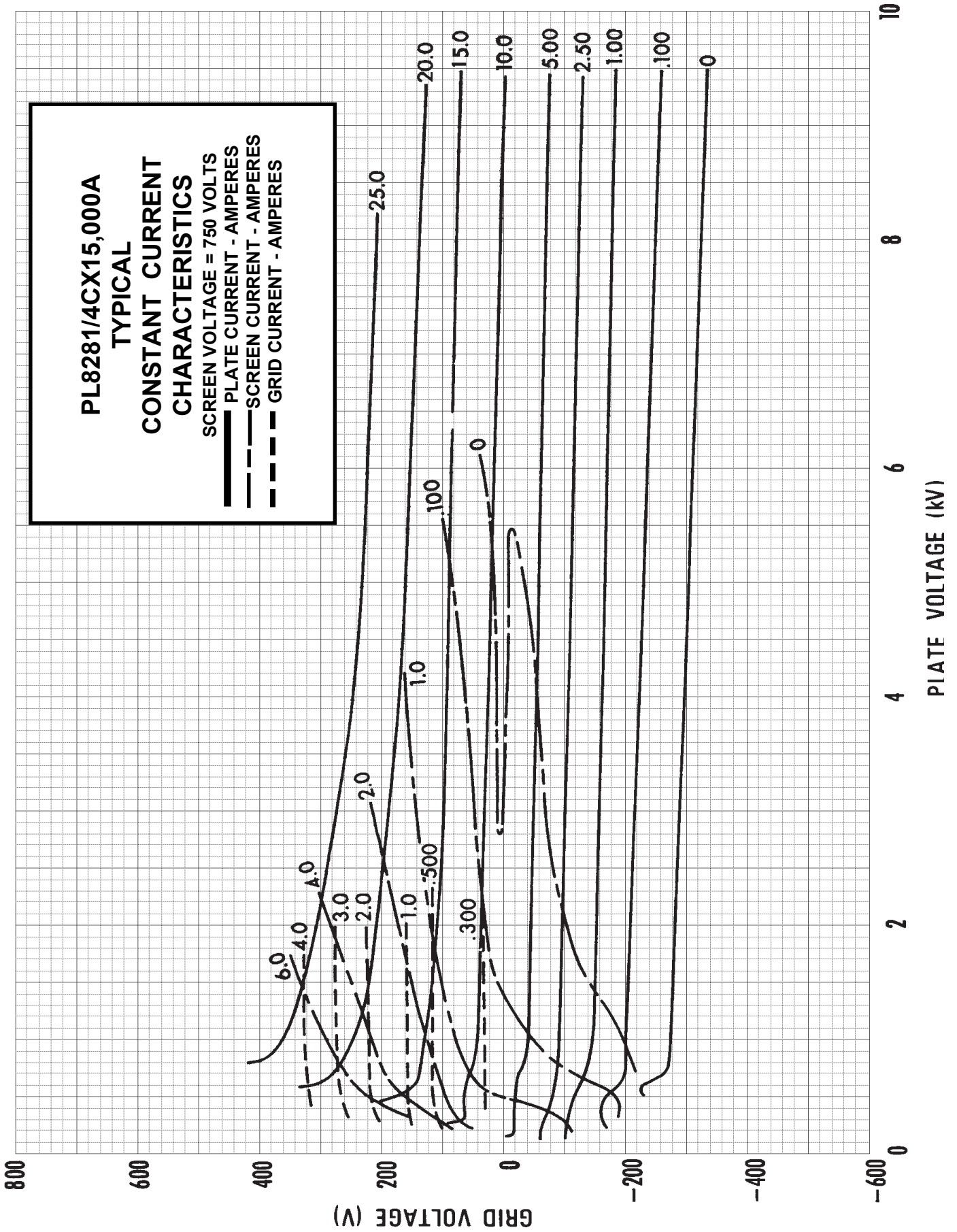



PL8281/4CX15,000A

